

Operating Instructions



F101 - Fuel Cell H_2/O_2

F102 - Double Fuel Cell H_2/O_2

F103 - Fuel Cell $H_2/O_2/Air$

F104 - Double Fuel Cell $H_2/O_2/Air$

Overview

Fuel Cell
 H_2/O_2 /Air

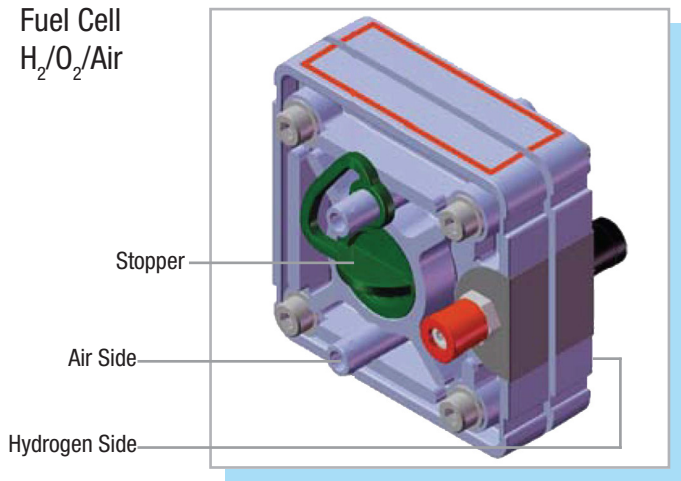

Fuel Cell
 H_2/O_2

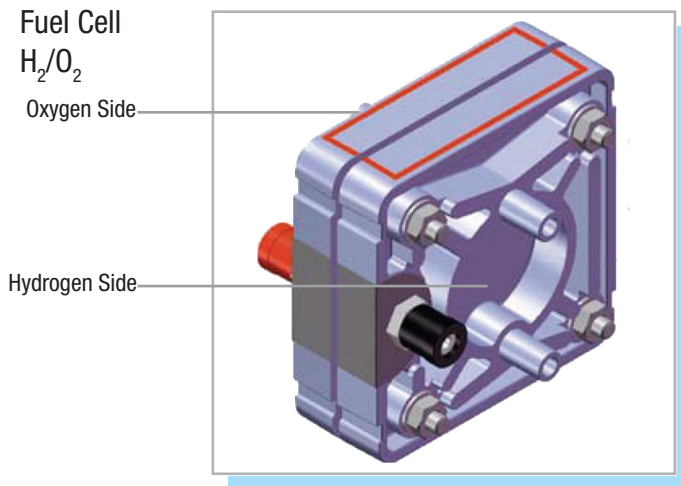

Setting Up

This PEM fuel cell (PEM = Proton Exchange Membrane) produces electricity by using hydrogen and oxygen gas (or atmospheric oxygen). Its only by-products are water and heat.

Read the Operating Instructions and the General Safety Precautions before using any of the equipment.

Fuel Cell - H₂/O₂ Set Up

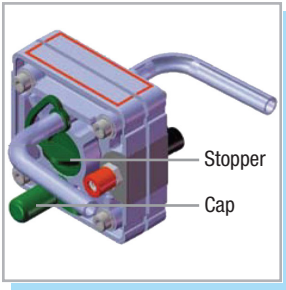

- Fit caps to the bottom outlets of the fuel cell.

NOTE: Make sure that the stopper is fitted to the air inlet.

- Connect the gas supply to the top gas connectors: hydrogen to the negative pole side (black), and oxygen to the positive pole side (red).
- Connect the electrical load. When doing so, make sure that the polarity is correct (red = "+", black = "-").
- The equipment is now ready for operation and can be used for demonstrations or experiments.

Fuel Cell - H₂/O₂/Air Set Up

When using Fuel Cell H₂/O₂/Air (F103) or Double Fuel Cell H₂/O₂/Air (F104), you also have the option of operating the cell in air-breathing mode simply by removing the stopper. When operating with atmospheric oxygen, the power of the cell is somewhat lower than when operating with pure oxygen.

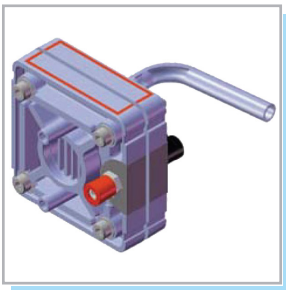

- Fit caps to the bottom outlet of the hydrogen output of the fuel cell.
 - Remove the stopper on the oxygen side of the fuel cell.
 - Connect the hydrogen supply to the negative pole supply (black).
- Note:** You do not need to connect anything to the oxygen side of the Fuel Cell.
- Connect the electrical load. When doing so, make sure that the polarity is correct (red = "+", black = "-").
 - The equipment is now ready for operation and can be used for demonstrations or experiments.

General Safety Precautions

- The units may only be set up and operated by a responsible supervisor.
- **WARNING!** Not suitable for children under 12 years!
- Read the Operating Instructions before setting up the fuel cell. Follow them during use and keep them readily available for reference.
- Wear protective goggles.
- Equipment and gases must be used and stored out of the reach of small children.
- Plug-in power supplies can be dangerous - they are not toys!
- Disconnect the unit from the plug-in power supply and the solar module before cleaning with liquids.
- Unless instructed to the contrary by the manual, do not reverse or short-circuit the connecting terminals.
- The units must not be operated when empty. Always ensure that they contain sufficient water. Pay attention to the water level marks.
- Remove flammable gases, vapours or liquids from the area surrounding fuel cells and electrolyzers. The catalytic materials involved may cause spontaneous ignition.
- Hydrogen and oxygen may escape from the units. Operate the units in wellventilated rooms to ensure that the gases do not accumulate and form explosive mixtures.
- The units may only be operated in display cases if adequate ventilation is guaranteed under all circumstances. The operator is responsible for ensuring this.
- Remove from the vicinity of the units anything that could ignite the hydrogen (e.g. open flame, materials that can become charged with static electricity, substances with a catalytic action).
- Remove from the vicinity of the units all substances that could spontaneously ignite in increased oxygen concentration.
- Do not smoke.
- Hoses, plugs and gas tanks are used for pressure compensation. They must not be fixed or secured with clamps, adhesive, etc.
- Only use the gas storage tanks associated with or supplied with the units. Never connect alternative gas storage tanks.
- The units may only be operated at room temperature and ambient pressure.
- Minimum separation distances must be observed when using solar modules and artificial lights.
- **WARNING!** The surface of solar modules can get very hot during extended operation.
- Make sure students know about any potential dangers and carefully supervise experimentation.
- Remove flammable gases, vapours or liquids from the area surrounding fuel cells and electrolyzers. The catalytic materials involved may cause spontaneous ignition.
- H-TEC Education accepts no responsibility for injuries or damage sustained in the event that these Safety Precautions are not followed.

Technical Data

F101:

H ₂ / O ₂ Power Range:	580 - 640 mW @ 1.5 A
Electrode Area:	3.6 cm ²
Permissible Voltage:	0.45 - 0.96 VDC
Permitted operating pressure:	0 - 20 mbar
Guide value for distilled water:	<2 µS/cm
H x W x D:	51 x 51 x 41 mm
Weight:	58 g

F102:

H ₂ / O ₂ Power Range:	1.2 - 1.3 W @ 1.5 A
Electrode Area:	3.6 cm ² X 2 cells
Permissible Voltage:	0.90 - 1.92 VDC
Permitted operating pressure:	0 - 20 mbar
Guide value for distilled water:	<2 µS/cm
H x W x D:	51 x 51 x 41 mm
Weight:	63 g

F103:

H ₂ / O ₂ Power Range:	580 - 640 mW @ 1.5 A
H ₂ / Air Power Range:	180 - 200 mW @ 375 mA
Electrode Area:	3.6 cm ²
Permissible Voltage:	0.45 - 0.96 VDC
Permitted operating pressure:	0 - 20 mbar
Guide value for distilled water:	<2 µS/cm
H x W x D:	51 x 51 x 41 mm
Weight:	58 g

F104:

H ₂ / O ₂ Power Range:	1.2 - 1.3 W @ 1.5 A
H ₂ / Air Power Range:	360 - 400 mW @ 375 mA
Electrode Area:	3.6 cm ² X 2 cells
Permissible Voltage:	0.90 - 1.92 VDC
Permitted operating pressure:	0 - 20 mbar
Guide value for distilled water:	<2 µS/cm
H x W x D:	51 x 51 x 41 mm
Weight:	63 g

Troubleshooting

The fuel cell has very little power.

Possible Cause:

- The fuel cell was stored too dry or for too long. A fuel cell with a dry polymer electrolyte membrane (PEM) loses power.

Solution:

- Continue operation. The fuel cell moistens itself during operation which slowly allows it to reach its full capacity again.

Despite hydrogen being present, the load connected to the fuel cell (e.g. the fan) is not working.

Possible Cause:

- Water has entered the fuel cell during operation (e.g. through the gas storage tanks). Drops of water in the fuel cell can block the gas feed and lead to rapid loss of power.

Solution:

- Dry the fuel cell by opening and blowing out the connections.

CAUTION

Risk of damage from compressed air
The use of compressed air for drying the fuel cell can cause irreparable damage to the fuel cell.
Only blow out the fuel cell for drying without technical tools.

Despite correct setup, the fuel cell is not working.

Possible Cause:

- No distilled water was used. The electrolyser and/or the fuel cell has/have sustained irreparable damage.

Should the above-mentioned solutions not remedy the cause of error, please contact H-TEC EDUCATION.

Shutting down

- Continue operating the fuel cells until the consumer (e.g. the motor) stops independently. This allows some water to remain in the fuel cell, moistening the PEM. This procedure also prevents unnecessary discharge of hydrogen.

Before putting the product into storage, observe the following points:

- Close the connections of fuel cells and electrolyzers with caps. This prevents the PEM from drying out. The same applies to stoppers on fuel cells.

Maintenance

The components of the product do not require maintenance. The following points should be observed, though:

- Use freshly distilled water for each operation.
- After operation, remove the water from the gas storage tanks.

Disposal

Do not dispose of fuel cells and electrolyzers as general household waste.

WARNING

Fire hazard from catalytic substances

The catalysts for the electrodes of fuel cells and electrolyzers promote burning when they come into contact with flammable substances. Avoid contact with hydrogen, alcohol fumes or other organic fumes. Ensure correct disposal.

According to European regulations, used electric and electronic devices may no longer be disposed of as unsorted household waste. The symbol of the crossed-out wheelie bin indicates the requirement for separate disposal.

Your local waste management company can provide you with additional information about disposal options.



© H-Tec Education, 2019. No part of this guide may be reproduced in whole or in part in any manner without the express written permission of H-Tec Education. Subject to technical changes.

H-TEC EDUCATION
1902 Pinon Dr. Unit B
College Station, TX 77845
USA

Phone: +1 979-703-1925

Fax: +1 979-314-1122

Email: sales@myhtec.com

Website: www.myhtec.com